



Project: _____ Item #: _____ Config #: _____

Evo® EVent® 48E PLUS - Electric Cooktop in Ventless Recirculating Ventilation System

Model #: 10-0600-EVTModel 10-0600-EVT
w/ 36" Casters Shown

DESCRIPTION

The Evo EVent® 48E PLUS is an electrically controlled 48" x 24" (1219mm x 610mm) rectangular steel cooktop in an integrated ventless recirculating ventilation unit. Evo EEvents six combined heaters heat a static cooking zone with variable temperatures ranging from 100°F to 425°F (38°C to 218°C). A high velocity CFM ventless system provides containment and capture from the intake aperture located on the chef-side adjacent the cooking surface, and a discharge duct on the chef-side returns clean filtered air. The duct system is fully welded stainless steel and utilizes a 4-stage filtration system including a washable stainless steel grease baffle filter, mesh particulate filter, electrostatic precipitator, and a replaceable activated charcoal filter. Factory installed fire suppression system with dry contact fire alarm micro switch and cross-pattern nozzles provide a continuous zone of fire protection.

SPECIFICATIONS

FILTRATION - Completely self-contained 4-stage filtration process reduces grease emissions below that are allowed in NFPA 96 and ANSI UL710B using the EPA 202 test method. The self-contained 4-stage filtration system includes a washable stainless steel grease baffle filter, mesh particulate filter, electrostatic precipitator (ESP) and replaceable activated charcoal filter. All filters are easily removable with the included 8 MM hex key. Airflow sensors continually monitor airflow and grease removal while an interlock system will not allow unit to operate if filters are missing, clogged or in the event of a fire.

FIRE PROTECTION - Factory installed Buckeye® Kitchen Mister system includes BFR-5 tank, 2 - nitrogen cartridges, SRM control head, piping, flex cable, fusible link, nozzles and manual pull station. Manual pull is located on the chef side (front) of the unit. BFR-5 tank comes pre-filled (charged) with fire suppression chemical. Fire protection system meets NFPA 96 Chapter 13 and was tested to UL300 standards.

Fire protection system must be armed and certified by Buckeye® Authorized distributor after installation and before first use (operators responsibility).

EXHAUST AND AIR FLOW - Exhaust air is horizontal discharge. A minimum of 70 cubic feet (CFM) of fresh air per minute is required both in and out of cooking area to ensure the dilution of cooking aromas. Dedicated Make-up Air unit is not required. Please consult your HVAC contractor.

COOKING APPLIANCE - The 48E PLUS unit includes a 48" x 24" (1219mm x 610mm) flat rectangular steel cook surface with Evo® patented intelligent heating technology that provides a 36" x 17" heated cooking area. Each unit also includes a resistive touchscreen display that provides feedback on the operation of the unit.

STANDARD FEATURES

- 48" x 24" (1219mm x 610mm) flat rectangular steel cook surface
- 6 combined heaters for high capacity throughput
- Variable temperatures 100°F to 425°F (38°C to 218°C)
- Completely self-contained, 4-stage filtration system
- Resistive interactive touchscreen display that provides instant status of filters, grease drawers and control of temperature presets
- Stainless steel and aluminum construction for durability, strength and ease of cleaning
- Can be factory configured for 36" or 34" overall counter height
- Large removable grease collection tray
- Self-contained filtration process reduces emissions below that allowed in NFPA 96 and ANSI UL710B using the EPA 202 test method
- Pre-engineered factory installed fire protection system
- Fire protection system includes a dry contact micro switch for connection to a central fire alarm system (operators responsibility)
- Low noise with only 70 dBA average
- Evo EEvents are semi-mobile, making them easy to roll out for housekeeping and maintenance
- Chef-side accessible washable stainless steel grease baffle filter, mesh particulate filter, electrostatic precipitator (ESP) and disposable activated charcoal filter
- Charcoal filter recommended replacement interval - 2 weeks
- Available in 208 V, 3-phase
- 8-foot cord and molded NEMA 15-50P
- Units ship with one complete set of 4 filters, grill surface cleaning kit, 2 stainless steel spatulas, grill scraper, and owner's manual
- Limited one-year parts and labor warranty

AVAILABLE PARTS

- 10-0150-EVT-34 34" Caster Kit - ADA Compliant
- 10-0150-EVT-36 36" Caster Kit - Standard
- 10-0150-EVT-FMS Stainless Steel Surround
- 13-0200-EVT Electrostatic Precipitator (ESP)
- 13-0210-EVT Stainless Steel Grease Baffle Filter
- 13-0220-EVT Aluminum Mesh Pre-Filter
- 13-0230-EVT Replaceable Charcoal Filter
- 20-EVT-1100 Recommended Spare Parts Kit

CERTIFICATIONS



UL710B LISTED



Evo America, LLC 20360 SW Avery Ct., Tualatin, OR 97062

Ph 503-626-1802 • Fax 503-213-5869 • evoamerica.com • sales@evoamerica.com

Evo is protected under U.S. Patents 9,897,328, 9,869,474, 10,139,113, 9,903,595, 10,842,540, 7,825,353 and U.S. Patents Pending.

NOTE: Due to ongoing product improvement, specifications are subject to change without notice and are not intended for installation purposes.



Evo® EVent® 48E PLUS - Electric Cooktop in Ventless Recirculating Ventilation System

Model #: 10-0600-EVT

NOTE: Specifications are subject to change without notice.

ENVIRONMENTAL SPECIAL NOTICE: The ventilation system is designed to eliminate grease laden vapor & smoke and reduce odor but not eliminate odors. Air exchange at the installation site must comply with requirements of the local jurisdictional authority. To ensure dilution of odor buildup, minimum recommendation is 70 to 140 cubic feet (CFM) of fresh air per minute both in and out of the cooking area.

MINIMUM CLEARANCE FROM UNIT TO NEAREST COMBUSTIBLE SURFACE (UNIT MUST BE SERVICEABLE FROM ALL SIDES)				
	Back (Guest)	Side	Front (Chef)	Top (Minimum Ceiling)
Inches	0"	0"	36" recommended 24" minimum	96" minimum ceiling height A.F.F (Above Finish Floor)
(MM)	(0)	(0)	(914) recommended (610) minimum	(2438) minimum ceiling height A.F.F (Above Finish Floor)

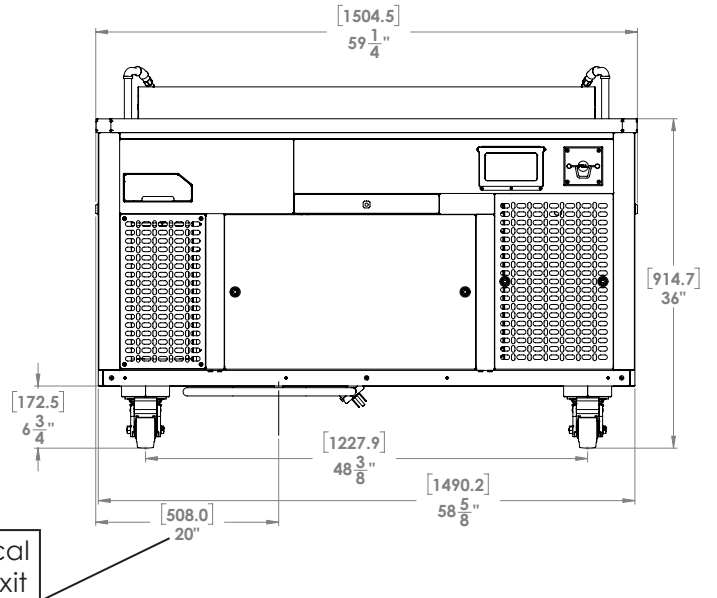
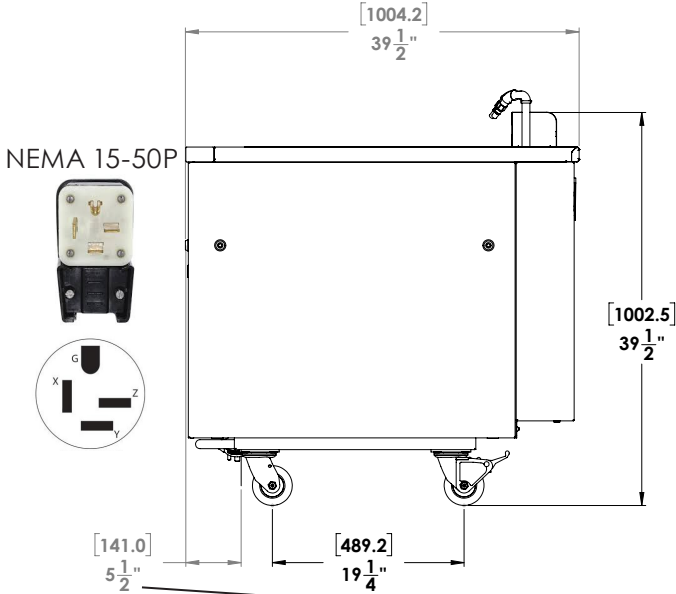
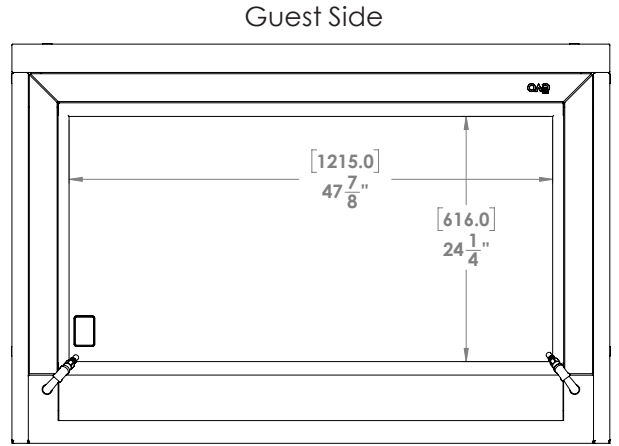
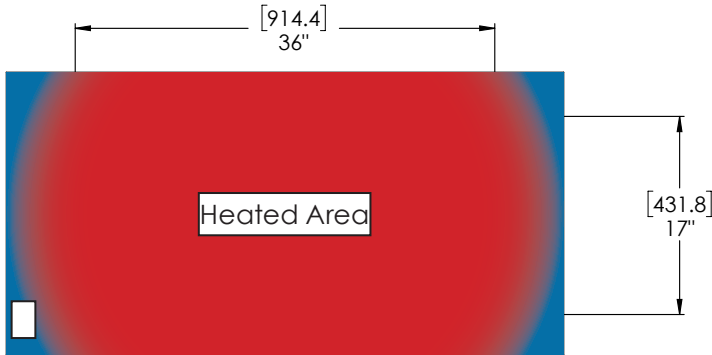

Model	Cooking Surface	Chassis Dimensions			Voltage & Phase	AMP Draw	Max Breaker	Plug Type	Weight (Ship)
		H	W	D					
10-0600-EVT	1152 Square Inches	36" or 34" 914mm 864mm	59.14" 1504mm	39.5" 1004mm	208V 3 Phase 60 Hz	32 AMPS	40 AMP (Dedicated)	NEMA 15-50P	857 lbs 388 kg (1235 lbs) (560 kg)

Evo America, LLC 20360 SW Avery Ct., Tualatin, OR 97062

Ph 503-626-1802 • Fax 503-213-5869 • evoamerica.com • sales@evoamerica.com

Evo is protected under U.S. Patents 9,897,328, 9,869,474, 10,139,113, 9,903,595, 10,842,540, 7,825,353 and U.S. Patents Pending.

Due to periodic changes in design, procedures, methods, regulations and policies, the specifications contained in this sheet are subject to change without notice. While Evo exercises good faith efforts to provide accurate information, we are not responsible for errors or omissions in information provided or conclusions reached as a result of using the specifications. By using the information provided, the user assumes all risks in connection with such use.

© Evo America, LLC 2021
All Rights Reserved



> DESIGN & INSTALLATION CONSIDERATIONS

Positioning the Unit – Clearance

- Evo EVent® arrives palletized & strapped in a heavy corrugated shipping carton. Once unpacked, it is important to have adequate clearance to move and position the unit in place. Allow minimum of 42" (1066.8mm) opening into the space or building to place unit inside. If not possible, unit can be rigged, lifted off its casters and rolled to its back side (Guest Side, see page 2). All loose components and large access panels removed to allow for smaller door clearances.
- If EVent® is installed into a cart or cabinet, the chef's side (touchscreen control, fire pull station, inlet aperture) should be facing out, accessible to cooking staff and unobstructed.

Electrical Outlet & Fire Alarm Placement Clearances

- Unit is equipped with factory installed cord and plug. If final electrical connection is located on floor, the receptacle needs to be flush with the final floor finish to allow unit to roll easily over plug. If unit is hard wired, flexible conduit with adequate length will need to be installed to allow for housekeeping.
- If building fire alarm is required, the above considerations apply.

Sneeze Guard Installation

- Allow a minimum 1" (25.4mm) air space from counter to bottom of glass for creation of an "air curtain". 4" (101.6mm) additional clearance from wall to unit if guest side is installed against wall.

Ventilation Considerations

- The HVAC system plays a large part in the efficiency of the Evo EVent® unit. The HVAC system should be designed to allow adequate cooling load for the dining space, while minimizing the velocity of air exiting the diffusers.
- If velocity is unavoidable, diffusers should be positioned to direct air away from the Evo EVent® cooking surface. Air blowing across the cooking surface will inhibit the designed capture of smoke and grease laden vapor.
- A minimum of 70 cubic feet of fresh air per minute is required both in and out of cooking area to ensure the dilution of cooking aromas. Dedicated Make-up Air unit not required. Please consult your HVAC contractor.

Acoustic Considerations – Dining Space

- Although Evo EVent® with its integrated ventilation system brings customers closer to the cooking experience by eliminating the need for noisy ventilation hoods, certain surfaces can reflect, rather than absorb ambient noise. If hard surface finishes (i.e. stone, glass) are used throughout the space, softer surfaces may need to be introduced to absorb reflecting sounds and noise.